

# CASTON II/III/III PLUS

## Crane Scale

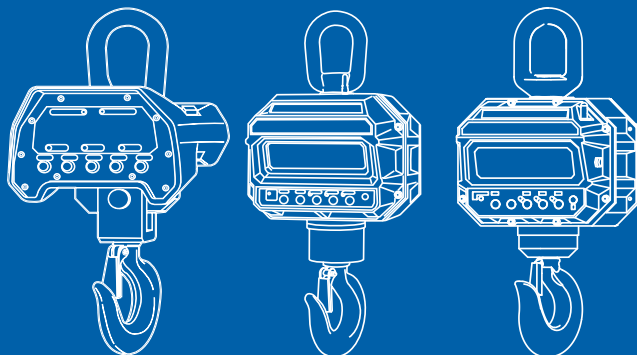

# CAS

# CONTENTS

<b>1. PRECAUTIONS.....</b>	<b>6</b>
<b>2. OVERALL VIEW .....</b>	<b>7</b>
<b>3. DISPLAY &amp; KEY FUNCTIONS.....</b>	<b>10</b>
<b>4. BATTERY USAGE .....</b>	<b>12</b>
<b>5. FUNCTIONS &amp; DESCRIPTIONS.....</b>	<b>15</b>
<b>6. SET Mode Description.....</b>	<b>17</b>
(1) AP MODE .....	17
(2) SB MODE .....	17
(3) BA MODE .....	18
(4) CO MODE .....	18
(5) ID MODE.....	19
(6) BR MODE .....	19
(7) HL MODE .....	20
<b>7. Communication Protocol &amp; Command.....</b>	<b>21</b>
<b>8. REMOTE CONTROL.....</b>	<b>23</b>
<b>9. TWN (OPTION).....</b>	<b>24</b>
<b>10. PRODUCT SIZE(CASTON-II).....</b>	<b>25</b>
<b>11. ERROR MESSAGE .....</b>	<b>30</b>

# Warning

Turn power switch off on rear panel when you don't use the scale for a long time.

**Do not disassemble the scale.**

When any damage or defect occurs, contact your CAS authorized dealer immediately for proper repair.



**Do not overload beyond the maximum weight limit.**

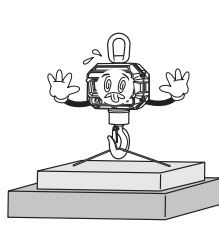

**Scale must be grounded to minimize electricity static.**

This will minimize defect or electric shock.

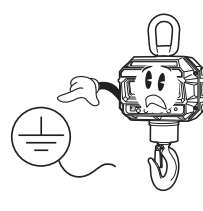

**Do not pull the plug by its cord when unplugging.**

Damaged cord could cause electric shock or fire.

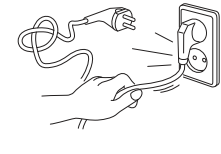

**To prevent from fire occurring, Do not place or use the scale near flammable or corrosive gas.**

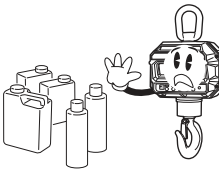

**To reduce electric shock or incorrect reading, Do not spill water on the scale or place it in humid condition.**

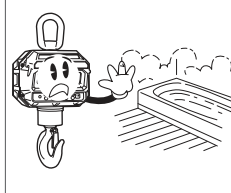

**Avoid placing the scale near heater or in direct sunlight.**

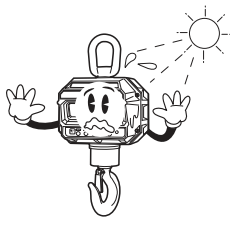

**Insert plug firmly to wall outlet to prevent electric shock.**

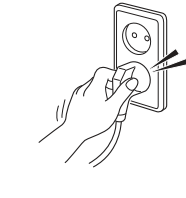

**Use proper Adapter.**

Incorrect adapter could damage the scale.

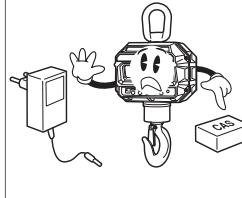

# Attention

Do not stand under the scale while weighing the load, and you should be careful to provide against a safety accident. To install, safety pin in hook should be fixed to prevent dropping out from lift eye bolt.

For consistent and accurate reading, maintain periodical check by your CAS authorized dealer.

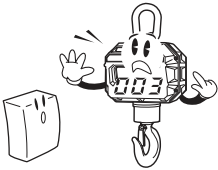

Avoid sudden shock to the scale.



Take the battery out when scale is not in use for long time. Leakage from the batteries is hazardous.

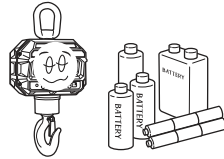

Place the scale on firm and temperature consistent environment.

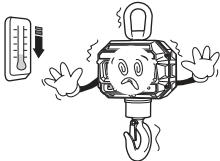

Keep the scale away from other electromagnetic generating devices.

This may interfere with accurate reading.

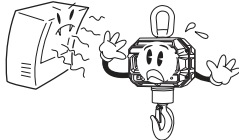

# 1. PRECAUTIONS



**WARNING:** The load which hang on the hook should be a vertical load. (Refer to the next features.)

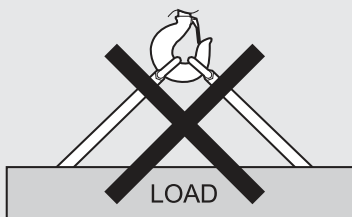
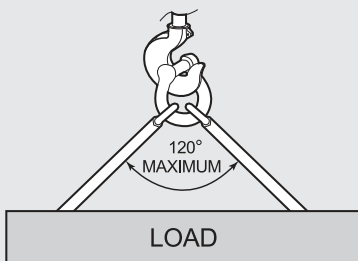

- The load which hang on the hook should be a vertical load.

## 2. OVERALL VIEW

### (1) CASTON-II

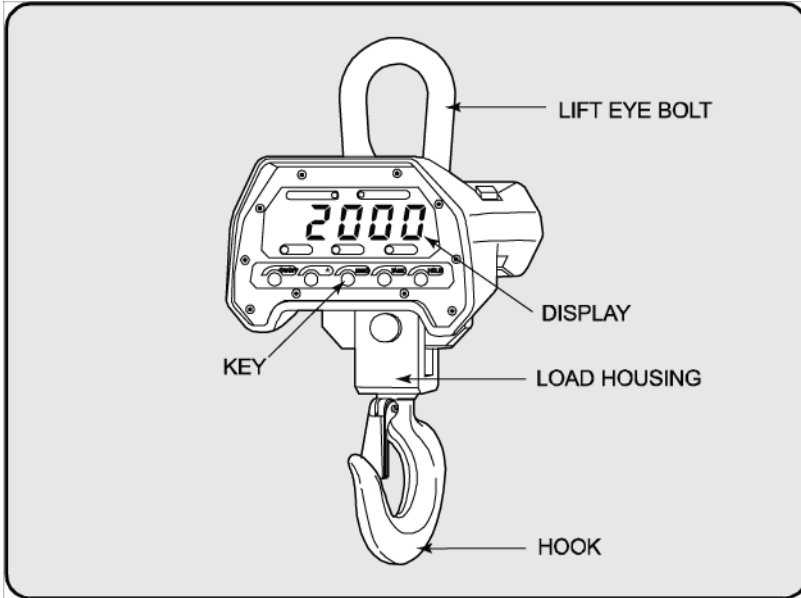

## SPECIFICATIONS

MAX. TARE WEIGHT	FULL TARE
DISPLAY	L.E.D(1.2 inch)
OPERATION TEMPERATURE	- 10°C ~ +40°C
POWER SOURCE	DC 6 V Rechargeable Battery / AC Adaptor
POWER CONSUMPTION	0.6 ~ 1W
DISPLAY LAMP	ZERO, TARE, HOLD, LOW BATTERY LAMP
CONTINUOUS USING TIME	60 HOURS

## (2) CASTON-III

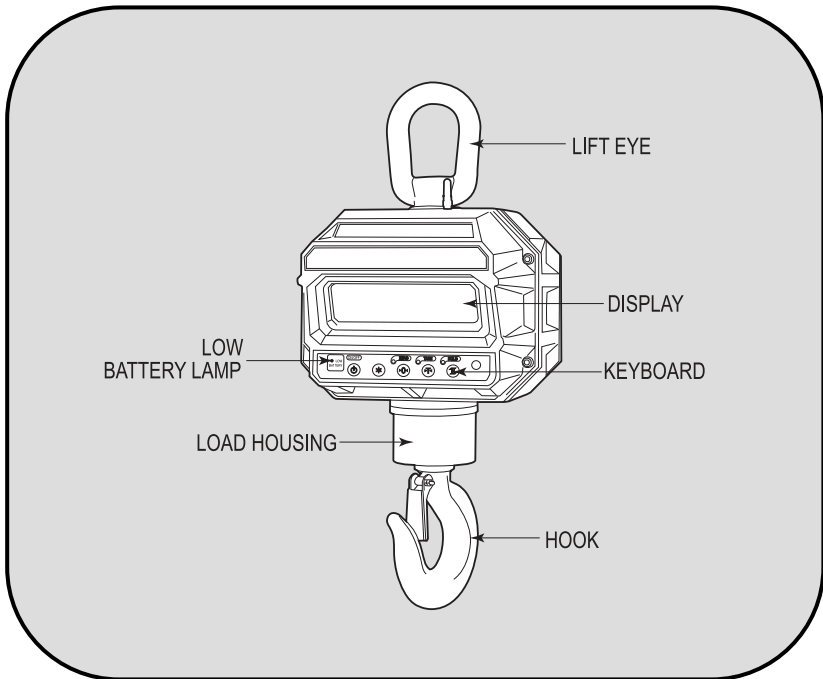

## SPECIFICATIONS

MAX. TARE WEIGHT	FULL TARE
DISPLAY	L.E.D(1.5 inch)
OPERATION TEMPERATURE	- 10°C ~ +40°C
POWER SOURCE	DC 12 V Rechargeble Battery / AC Adaptor
POWER CONSUMPTION	1.2 ~ 2.4W
DISPLAY LAMP	ZERO, TARE, HOLD, LOW BATTERY LAMP
CONTINUOUS USING TIME	40 HOURS

### (3) CASTON-III PLUS

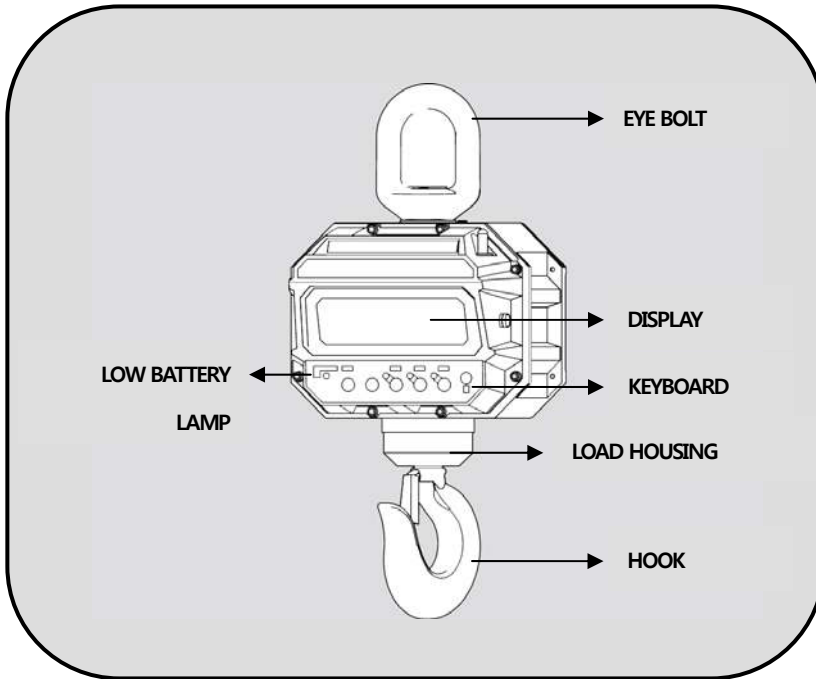

### SPECIFICATIONS

MAX. TARE WEIGHT	FULL TARE
DISPLAY	L.E.D(1.5 inch)
OPERATION TEMPERATURE	- 10°C ~ +40°C
POWER SOURCE	DC 12 V Rechargeble Battery / AC Adaptor
POWER CONSUMPTION	1.2 ~ 2.4W
DISPLAY LAMP	ZERO, TARE, HOLD, LOW BATTERY LAMP
CONTINUOUS USING TIME	40 HOURS

### 3. DISPLAY & KEY FUNCTIONS

\*CASTON-II

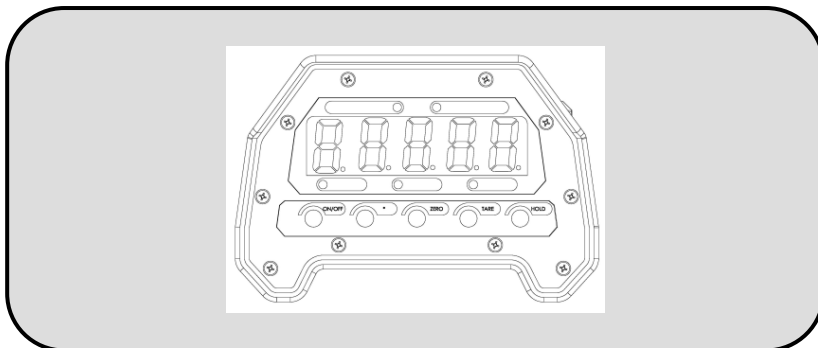

\*CASTON-III

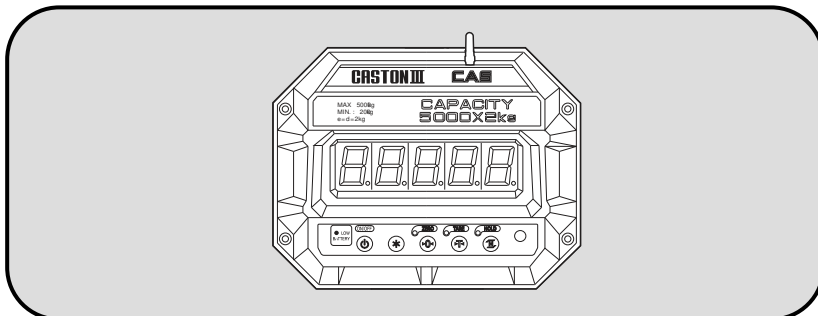

\*CASTON-III PLUS

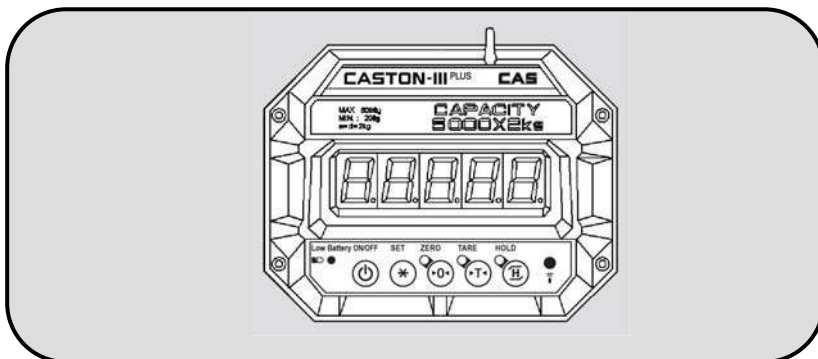

## ■ DISPLAY

WEIGHT DISPLAY: Displays weight or messages (5 Digit).





ZERO LAMP: Indicates that scale is stable and at zero.

NET LAMP: Indicates that scale is currently using a tare.

HOLD LAMP: Indicates that the HOLD function is activated.

LOW BATTERY LAMP: Indicates that voltage of battery low and should be changed soon.

## ■ KEY FUNCTIONS

KEYS	FUNCTIONS
	Used to turn the scale ON / OFF or used to released from AP/HL mode
	Used to reset the scale zero or enter the AP mode
	Used to activate tare function and to clear tare entry
	Used to weigh unstable things (livestock, liquid, etc.) or used to store the set value in 'AP/HL' mode
	Used to increase the set value in 'AP/HL' mode



**WARNING:** Do not press the keys with excessive force, the keys are to be pressed with a soft touch.

## 4. BATTERY USAGE

### (1). CASTON-II

- Couple connector in main body with connector in battery portion.
- Insert battery portion to the main body and turn fixing bolt to the right to fix.
- If the battery is neglected for a long time or not use without charging, it may effect on battery life. (recommended charging period : once a month)

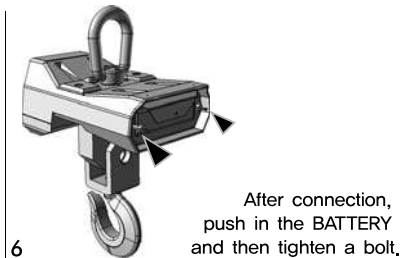
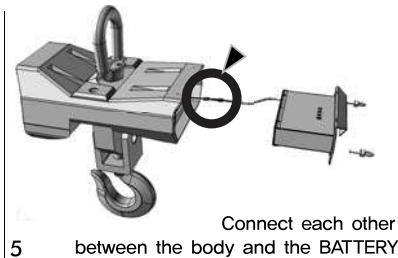
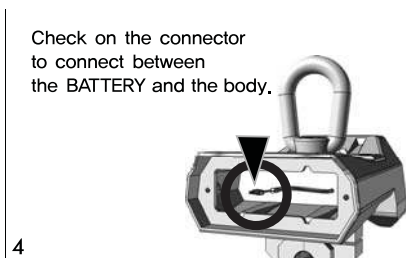
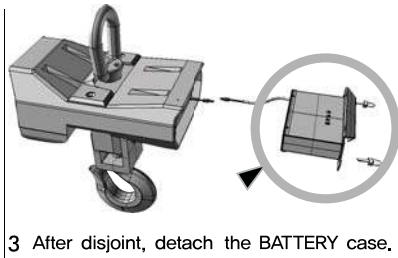
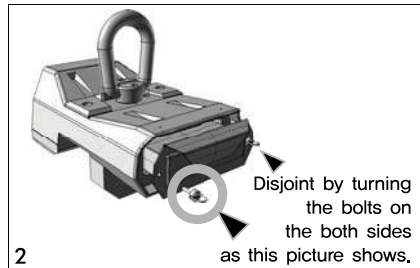
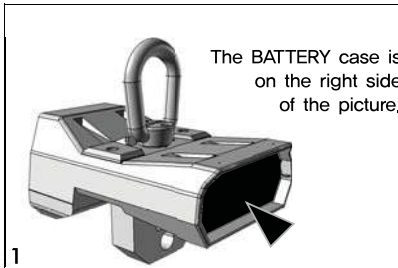

- To prevent battery discharge, CASTON-II is disconnected with the battery.
- Please connect the battery to use after opening the product as shown above.

## (2). CASTON-III

- Open the battery lid located in back of the scale and turn main switch off.
- Separate the battery connector and take out the discharged battery.
- Put a charged battery in rear and connect the battery connector.  
Turn main power switch on and cover the battery lid.

- **The drop of battery voltage can affect the brightness of display.  
To prevent this, the regular battery recharging is recommended.**
- **In case the battery will be left without recharging for a long time, it is desirable the main power switch is set off. Otherwise, it also can affect the battery life.**

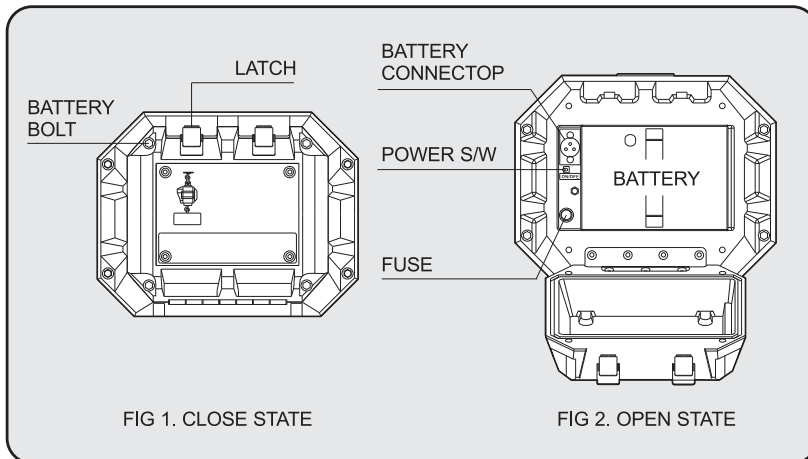

### (3). CASTON-III PLUS

- The drop of battery voltage can affect the brightness of display.  
To prevent this, the regular battery recharging is recommended.
- In case the battery will be left without recharging for a long time, it is desirable the main power switch is set off. Otherwise, it also can affect the battery life.

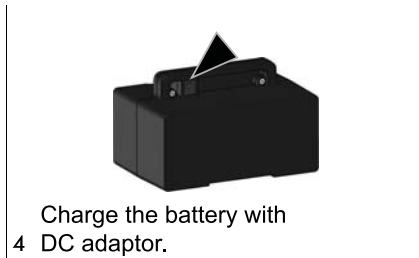
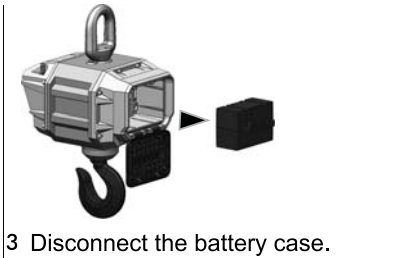

## 5. FUNCTION & DESCRIPTIONS

### 1. POWER ON

- Press the ON key located in real panel of the scale.  
(While the power is off, the ON/OFF key on the remote control wouldn't operate.)
- Press **ON/ OFF** key.
- LED display will be on and then, it will show from 00000 to 99999 continuously

### 2. POWER OFF

- Press ON/OFF key
- LED display will show off message and then power turns off

### 3. ZERO FUNCTION

- Used to correct drifted zero value when the scale is unloaded motion is not detected  
You can adjust the zero up to  $\pm 2\%$  of the maximum capacity
- The function does not work when weight is fluctuated or unstable.

### 4. TARE FUNCTION

- Use tare function after removing the weighing material from container being used.
- The function does not work when weight is fluctuated or unstable.
- The weight including TARE weight can't exceed the maximum capacity.

## 5. HOLD FUNCTION

**There are three HOLD functions : Average / Manual / Peak Hold function  
To use this function , must be check Hold-type of 'HL' mode.**

### ■ Do Not Use Hold (HL -> 0)

- Do Not Use Hold.

### ■ Auto Hold (HL -> 1)

- Press the HOLD key before weighing an unstable item
- "AHold" will display and then, HOLD lamp is on.
- The averaged value of the weight fluctuation will be displayed after few seconds.

### ■ Peak Hold (HL -> 2)

- Press the HOLD key while checking peak value.
- "PHold" will display and then, peak value of the weight will be updated continuously until HOLD function is released

### ■ Average Hold (HL ->3)

- Press the HOLD key while weighing an unstable item
- "Hold" will display and then the averaged value of the weight fluctuation will be displayed after few seconds.

### ■ Release of Hold Functions

- Press the HOLD key while HOLD functions are activated
- Remove item on the hook.
- hdoFF will display and then, the scale return to normal weighing mode.

## 6. SET Mode Description.

### (1) AP MODE

Press ON key while ZERO key is pressed, then you can enter into 'AP' mode. ('AP' means 'Auto Power off')

#### ■ Key Usage

<b>STAR KEY</b>	Used to increase the input value
<b>HOLD KEY</b>	Used to save the input value and Return to Normal Mode.
<b>ZERO KEY</b>	Go to Next Mode.

#### ■ Setting Menu

DISPLAY	FUNCTION
AP-00	Not use
AP-10	Power off after keeping '0'kg 10 minute
AP-20	Power off after keeping '0'kg 20 minute
AP-30	Power off after keeping '0'kg 30 minute

### (2) SLEEP MODE

Press ON key while ZERO key is pressed and Press ZERO Again, then you can enter into 'SLEEP' mode. ('Sb' means 'SLEEP'.)

#### ■ Key Usage

<b>STAR KEY</b>	Used to increase the input value
<b>HOLD KEY</b>	Used to save the input value and Return to Normal Mode
<b>ZERO KEY</b>	Go to Next Mode.

#### ■ Setting Menu.

DISPLAY	FUNCTION
<b>Sb-00</b>	Sleep mode is deactivated.
<b>Sb-20</b>	Sleep mode is activated after 20 seconds.
<b>Sb-40</b>	Sleep mode is activated after 40 seconds.
<b>Sb-60</b>	Sleep mode is activated after 1 minute.

### (3)BA MODE

Press ON key while ZERO key is pressed and Press ZERO Twice, then you can enter into 'bA' mode.

('BA' means 'Weight BACK up'.)

#### ■ Key Usage

<b>STAR KEY</b>	Used to change the input value
<b>HOLD KEY</b>	Used to save the input value and Return to Normal Mode

#### ■ Setting Menu

<b>DISPLAY</b>	<b>FUNCTION</b>
bA-oF	Weight Back Up OFF
bA-oN	Weight Back Up ON

### (4) CO MODE

Press ON key while ZERO key is pressed and Press ZERO Three times, then you can enter into 'CO' mode.

('CO' means 'Communication'.)

#### ■ Key Usage

<b>STAR KEY</b>	Used to change the input value
<b>HOLD KEY</b>	Used to save the input value and Return to Normal Mode

#### ■ Setting Menu

<b>DISPLAY</b>	<b>FUNCTION</b>
CO-CO	Use RS-232 Command Communication
CO-tU	Use Blue Tooth Communication with TW-100
CO-St	Use RS-232 stream.

## (5) ID MODE

Press ON key while ZERO key is pressed and Press ZERO Four times, then you can enter into 'ID' mode.

('ID' means 'Device ID'.)

### ■ Key Usage

<b>STAR KEY</b>	Used to change the input value
<b>HOLD KEY</b>	Used to save the input value and Return to Normal Mode

### ■ Setting Menu

DISPLAY (from 0 to 9)	FUNCTION
id- 0	Device ID 0
id- 9	Device ID 9

## (6) BR MODE

Press ON key while ZERO key is pressed, and Press ZERO Five times, then you can enter into 'BR' mode.

('BR' means 'Display Brightness'.)

### ■ Key Usage

<b>STAR KEY</b>	Used to increase the input value
<b>HOLD KEY</b>	Used to save the input value

### ■ Setting Menu

DISPLAY	FUNCTION
BR-00	The brightness is set to '0' (Dark)
BR-05	The brightness is set to '5' (Bright)

## (7) HL MODE

Press ON key while HOLD key is pressed, then you can enter into 'HL' mode. ('HL' means 'Hold type'.)

### ■ Key Usage

STAR KEY	Used to increase the input value
HOLD KEY	Used to save the input value

### ■ Setting Menu

DISPLAY	FUNCTION
HL-00	Do Not USE Hold
HL-01	Auto Hold / Manual Hold
HL-02	Peak Hold use
HL-03	Average Hold use

#### Notice :

While using the HOLD function, the weight displayed may be not exact.

## ※How to set Bluetooth.(With TWN)

(1) Turn on the 'POWER' (🔌) Key while pressing 'ZERO' (0) Key

Display : AP - 00

(2) Press 'ZERO' (0) Key three times, enter CO Mode.

Display : CO - CO

(3) Press 'STAR' (\*) Key , Set CO - Tu. ( Reset Bluetooth Modul )

(4) Press HOLD (H) Key. ( If Display 'Err', Press HOLD (H) Key again.

(5) Turn off the power, Repeat step (1)~(2) process.

(6) Select CO - CO, Press ZERO (0) Key. (To connect with TWN )

(7) Select id - 0, Press HOLD Key (H). ( To connect with TWN )

## 7. Communication Protocol & Command

### □ CAS Protocol (22 bytes) – ASCII Code

Ⓐ	Ⓑ	,	Ⓒ	Ⓓ	,	Ⓔ	Ⓕ	,	Weight Data (8byte)	Ⓖ	Ⓗ	Ⓘ	Ⓚ	Ⓛ
---	---	---	---	---	---	---	---	---	------------------------	---	---	---	---	---

Ⓐ Ⓑ	ST (Stable), US (Unstable), OL (Over Load)				
Ⓒ Ⓓ	GS (Gross), NT (Net)			Ⓔ	Device ID
Ⓕ	Blank	Ⓖ	Blank	Ⓗ	k
Ⓘ	g	Ⓚ	CR	Ⓛ	LF

Note. 1 Device No. is the successive value of ASCII code.

Ex) Device No. 01 : 0x31, Device No. 09 : 0x39, Device No. 13 : 0x3d

### Command Mode Protocol

Command (ASCII code)	Description	State
KT	Key Tare Value	Read / Write
WT	Current Weight	Read
ZE	Operating like the ZERO key	Read
TR	Operating like the TARE key	Read
HD	Operating like the ENTER key	Read
PR	Operating like the PRINT key	Read

**Read**

<b>1</b>	<b>2</b>	<b>3</b>	<b>4</b>	<b>5</b>
<b>Device ID</b>	<b>Command</b>		<b>CR</b>	<b>LF</b>

Note. 1 Device ID is hex and Command is ASCII

[Ex] Device ID is 3 when user want to know the current weight.

→write 03 57 54 0d 0a

**Write**

<b>1</b>	<b>2</b>	<b>3</b>	<b>4</b>	<b>5</b>	<b>6</b>	<b>7</b>	<b>8</b>	<b>9</b>	<b>10</b>
<b>Device ID</b>	<b>Command</b>	<b>KEY TARE</b>						<b>CR</b>	<b>LF</b>

Note. 1 Device ID is hex and DATA is ASCII

[Ex] When user want to input Key Tare Value (to 200).

→write 03 4B 54 30 30 32 30 30 0D 0A

[Ex] When user want to read Key Tare Value.

→write 03 4B 54 0D 0A

## 8. Remote Control

- ON/OFF: Button to operate power on/off.
- ZERO: Button to correct zero value.
- TARE: Used to tare value memorizing.
- HOLD: Used to weigh moving thing.
- CLEAR : Used to clear summing weight.
- SUM : Used to sum item

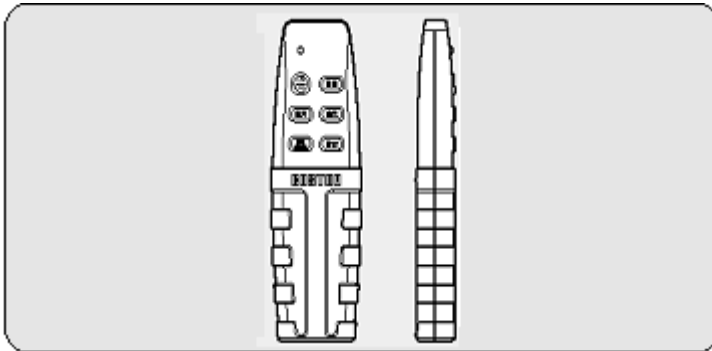

REMOTE CONTROL	
AVAILABLE DISTANCE	6m ~ 9m
AVAILABLE ANGLE	60°
POWER	3V(1.5V AMM x 2)

## 9. TWN (OPTION)

Please refer to handy terminal TWN manual of CASTON-Series

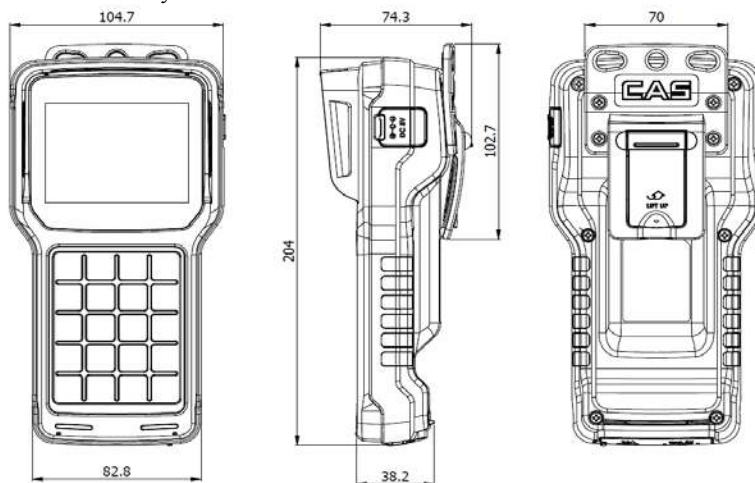

### 1. TWN Specification

Frequency	2.4GHz
Communication methods	ZIGBEE (BLUETOOTH)
Baud Rate	9600
Effective distance for communications	Maximum about 50~100M
Display	320*240 TFT LCD
Display below zero	“-” minus signal
Battery life time	Approx. 24hours
Battery changing time	Approx. 5~6 hours
Power	TWN : Rechargeable DC Battery 3.7V Charger: adapter for charging (4.2V 4400mA)
Temperature range	-10℃ ~55℃
Function	Printer interface, zero, tare, hold, print ID setting, weight sum.

# 10. PRODUCT SIZE

## (1)CASTON-II

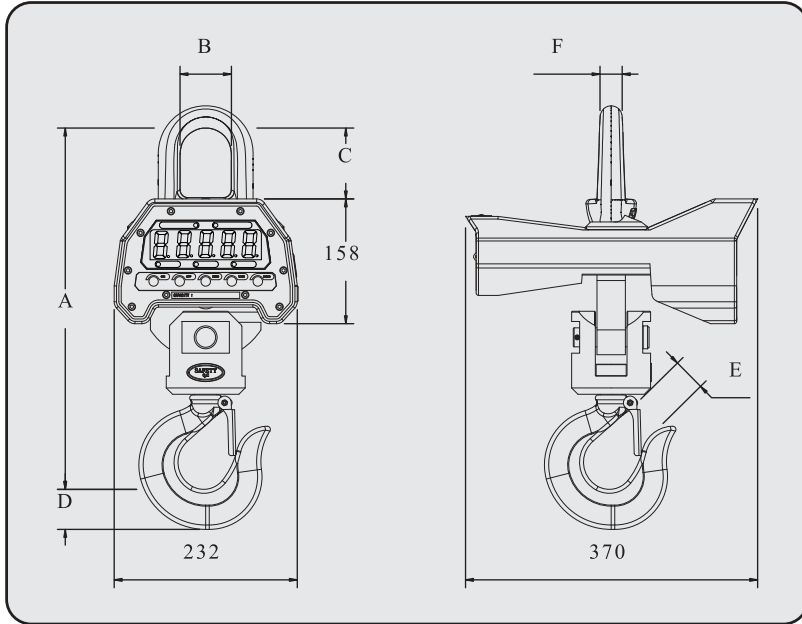

MODEL	MAX.CAPA	DIVISION	A	B	C	D	E	WEIGHT	F
0.5THB	500 kg	200 g	350	57.1	82	30	26	15 kg	26
	1000 LB	0.5 LB						6.8 LB	
1THB	1 TON	500 g	350	57.1	82	30	26	15 kg	26
	2000 LB	1 LB							
2THB	2 TON	1 kg	430	57.1	91	47	45	20 kg	30
	5000 LB	2 LB						9.1 LB	
3THB	3 TON	1 kg	430	57.1	91	47	45	20 kg(9.1 LB)	30
5THB	5 TON	2 kg	474	57.1	1	47	45	20 kg	30
	10000 LB	5 LB						9.1LB	

## (2). CASTON-III(B)

### 0.5 TON 5 TON

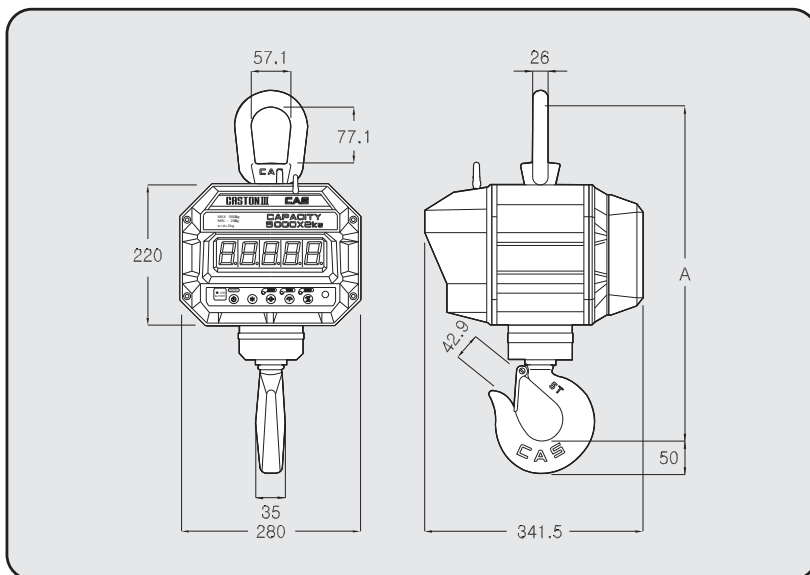

(UNIT: mm)

MODEL	MAX.CAPA	DIVISION	A	WEIGHT
0.5THD	0.5 TON	200 g	510	26 kg
1THD	1 TON	500 g	510	26 kg
2THD	2 TON	1 kg	515	28 kg
3THD	3 TON	1 kg	515	28 kg
5THD	5 TON	2 kg	538	31 kg

## 10 TON 50 TON(CASTON-III(B))

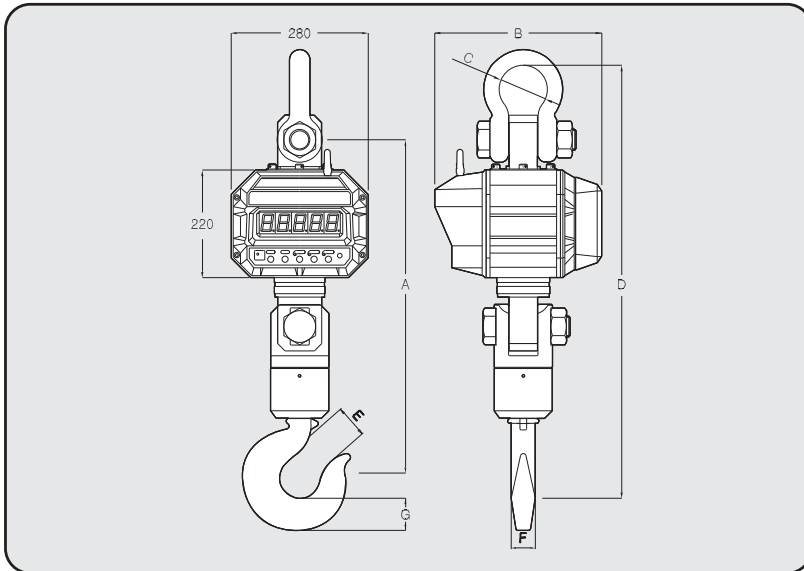

(UNIT: mm)

MODEL	MAX.CAPA	DIVSION	A	B	C	D	E	F	G	WEIGHT
10THD	10 TON	5 kg	667	360	∅83	845	57.2	42	57.2	44 kg
15THD	15 TON	10 kg	682	360	∅99	886	63.5	50	63.5	53 kg
20THD	20 TON	10 kg	725	360	∅126	990	86	60	86	76 kg
30THD	30 TON	20 kg	895	440	∅138	1200	108	92	108	220 kg
50THD	50 TON	20 kg	1400	440	∅180	1520	146	112.7	146	390 kg

### (3) CASTON-III PLUS

#### 2 TON 5 TON

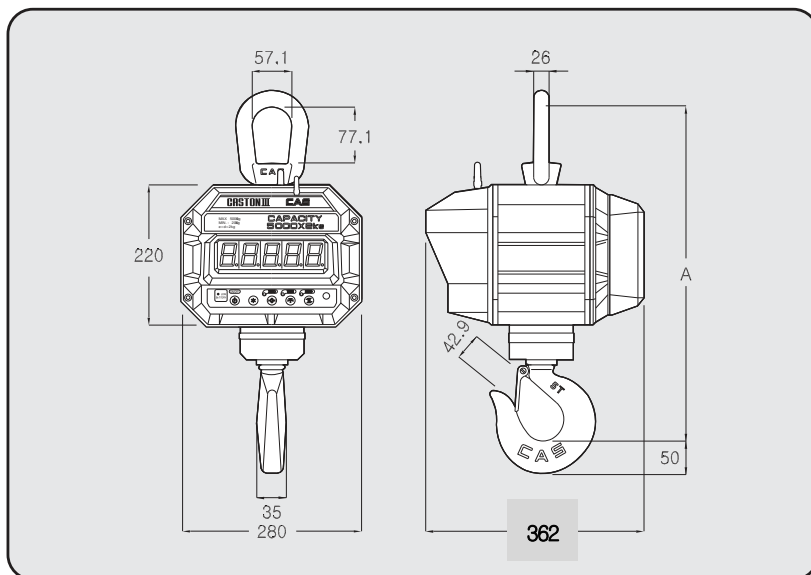

(UNIT: mm)

MODEL	MAX CAPA	DIVISION	A	WEIGHT
2THD	2 TON	1 kg	515	28 kg
3THD	3 TON	1 kg	515	28 kg
5THD	5 TON	2 kg	538	31 kg

# 10 TON 20 TON

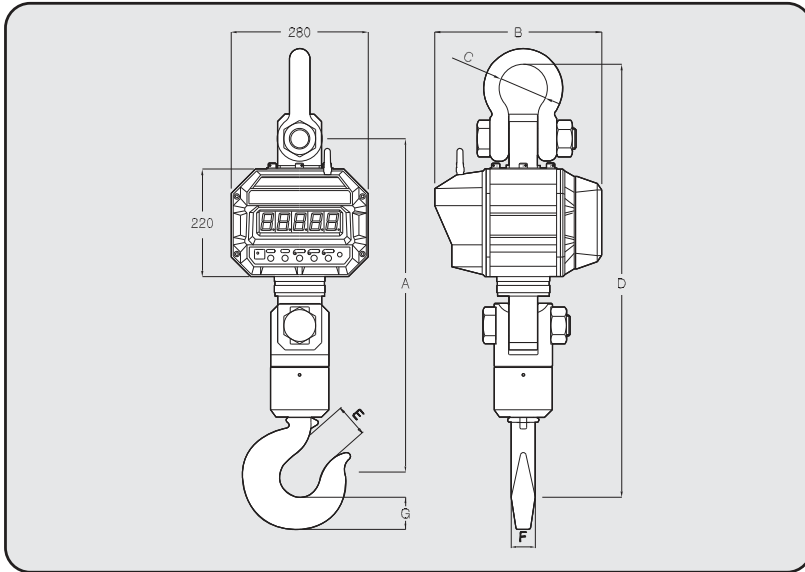

(UNIT: mm)

MODEL	MAX CAPA	DIVISION	A	B	C	D	E	F	G	WEIGHT
10THD	10 TON	5 kg	667	362	∅83	845	57.2	42	57.2	44 kg
15THD	15 TON	10 kg	682	362	∅99	886	63.5	50	63.5	53 kg
20THD	20 TON	10 kg	725	362	∅126	990	86	60	86	76 kg

## 11. ERROR MESSAGE

Error Message	Description	Solution
"Err 0"	The "Err 0" occurs when scale is not stable.	Remove unstable facts.
"Err 1"	The "Err 1" occurs when a current zero point has shifted from the last span calibration.	Please call your CAS dealer.
"Err 3"	The "Err 3" is an overload error.	Please remove the weight.

- Notice : Specifications are subject to change for improvement without notice.

# MEMO



# MEMO

# **CASTON II/III/III** <sup>PLUS</sup>

**Crane Scale**



**CAS BLDG., #1315, YANGJAE-DAERO,  
GANGDONG-GU, SEOUL, KOREA**

**TEL\_ 82 2 2225 3500**

**FAX\_ 82 2 475 4668**

**[www.globalcas.com](http://www.globalcas.com)**